



ICS*
Integrated Cockpit SYSTEM
Assembly

* The stem assembly is identical for ICS01, ICS01 0° and ICS01 Aero

INTEGRATED COCKPIT SYSTEM

Installation Manual (ICS01, ICS01 0°, ICS01 Aero)

By patiently following the guidelines below, the assembly process will lead to a functioning equipment with a high-performance, Swiss Engineered aesthetic.

Contents

1.	General Assembly Notes and Warnings	3
2.	Tools and Materials	3
3.	Stem Parts	4
4.	Frame Assembly	5
4.1	Brake Mounting	6
4.2	Cable Routing	7/8
4.3	Preparing and Installing Fork	9/10
4.4	Installing headset and ICS01 Stem	11
4.5	Finishing assembly	11

1. General Assembly Notes and Warnings

Due to the high level of integration of the Roadmachine 01 Integrated Cockpit, proper assembly requires a high degree of mechanical skill and specialized tools. It is critical that the assembly and maintenance is performed by a qualified professional.

In order to successfully assemble the Roadmachine 01 and the Integrated Cockpit it is important to follow the order of operations outlined in this guide. Failure to follow the outlined procedure can result in an assembly process that is more difficult than necessary and an end product that performs less than ideal.

WARNING: The Roadmachine 01 Integrated Cockpit (fork, stem, headset and stack spacers) are all proprietary components that cannot be substituted with non-specified components. Substitution of any of these components can compromise the integrity of the entire system and should under no circumstances be substituted. Failure to follow this warning can result in serious injury or death.

2. Tools and materials

Allen keys: 3, 4, 5mm

Open-end wrench: 7, 8mm

Brand-specific hydraulic tools

High quality grease

Carbon paste

Torque wrench

Steerer tube cutting guide

Carbon fiber cutting blade

PF-86 BB Installation tool

3. Stem Parts*

Integrated Cockpit Stem (ICS01)

ICS01 Stem (90/100/110/120/130)	1
Stem Faceplate	2
Cable guide	3
Stack spacers	4
IC Fork inserts	5
Cable cover	6
Cable clamp	7
Di2 Junction A mount (optional)	8

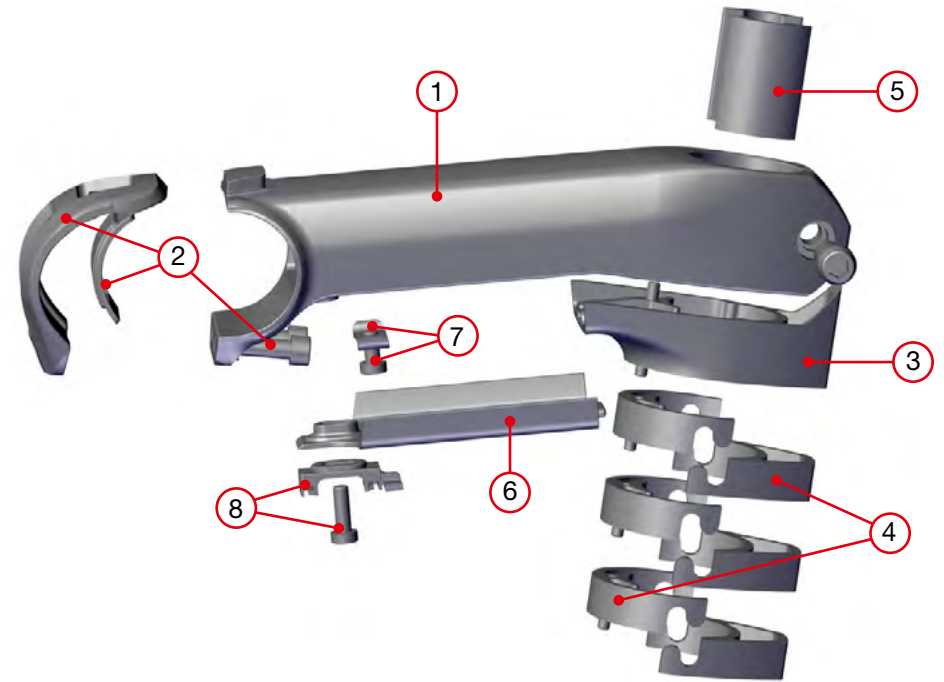

* The stem assembly is identical for ICS01, ICS01 0° and ICS01 Aero

4. Frameset assembly

4.1 Cable Routing

4.1.1 Brakes

Start the housing routing at the caliper and pass to the front

The rear brake hydraulic housing will pass UNDER the bottom bracket



Install the provided foam sleeve on the rear brake housing in the downtube



It is recommended to assemble the caliper-end hydraulic system (connector insert, olive, and inserting the threaded connector bolt) – this will help hold the hose in place during future assembly steps

4. Frameset assembly

4.2 Cable Routing

4.2.2 Drivetrain

- Install proper DTi frame fittings for your frame and drivetrain

Exemple: Roadmachine 01, 02



Downtube covers



Rear derailleur cable exit



BB cover

In the case of electronic systems, we strongly recommend assembling the system and checking all connections before routing cables through the frame.

Exemple: 01, 02 mechanical

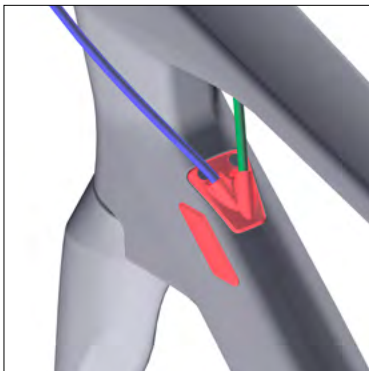

Drivetrain housing exit



Rear derailleur cable stop

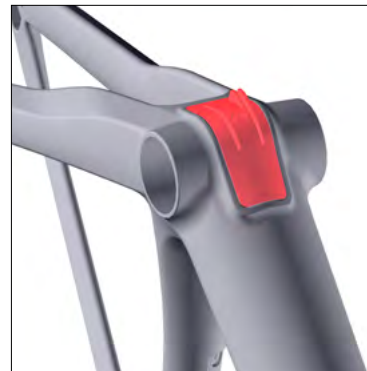

Rear derailleur cable stop

4. Frameset assembly

4.3 Preparing and Installing Fork

4.3.1 Measuring fork length

- Install the headset components, cable guide, stem, and steerer inserts.

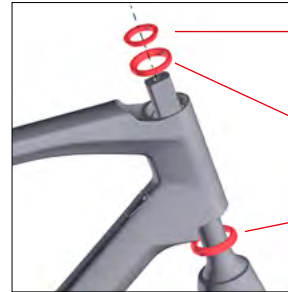

- Install steerer compression ring
- Install upper bearing
- Install lower bearing & fork

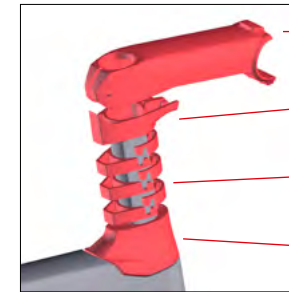

- Install stem
- Install stem cable guide
- Install stack spacers
- Install headset top cap

- Gently compress the system together and tighten the stem steerer tube clamp bolt gently.

△ **Warning:** without IC Fork steerer inserts, tightening the stem steerer clamp bolt can compromise the integrity of the steerer tube – leading to serious injury.

Verify the handlebar position!!



Install steerer spacers before tightening stem clamp!

- Using a felt-tipped marker, make a mark on the steerer tube at the top of the stem.
- After verifying handlebar position, and marking stem height, uninstall the fork and headset from the frame.



- Mark steerer at top of stem

4. Frameset assembly

4.3 Preparing and Installing Fork

4.3.2 Cut fork

- Use the mark on the steerer tube to assign a proper cutting location.

**Cut the steerer tube
3mm below the mark!**

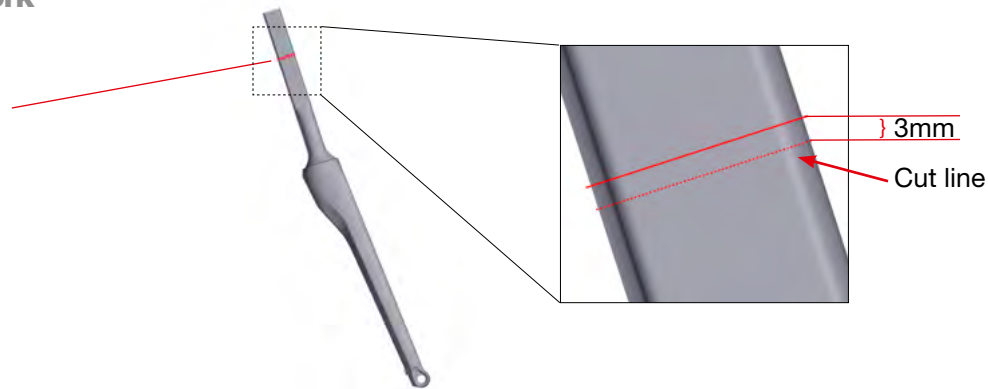

4.3.3 Install self-tapping compression nut

- The Roadmachine 01 IC Fork comes with an internal channel which receives a self-tapping compression nut.
- Install the self-tapping compression nut, making certain it remains aligned with the steerer
- Tighten until the top of the compression nut is flush with the top of the fork

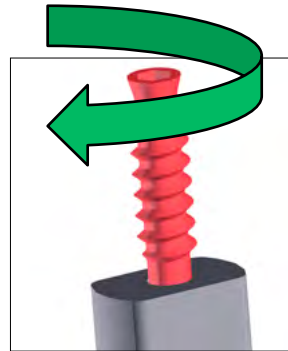

4.3.4 Route brake housing

- Route the housing through the internal guide, starting at the axle dropout and working towards the steerer tube.
- It is recommended to assemble the caliper-end of the hydraulic system (connector insert, olive, and inserting the threaded connector bolt) – this will help hold the hose in place during future assembly steps.

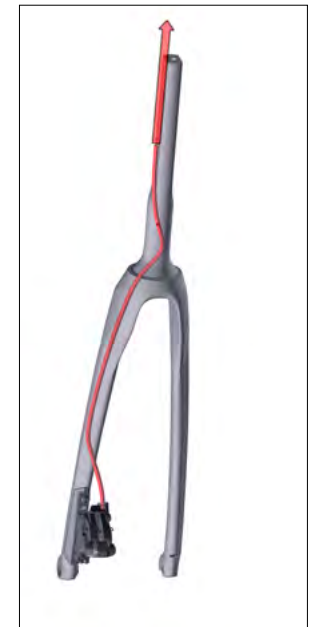

4. Frameset assembly

4.4 Installing headset and ICS Stem

- Install the fork and headset, using grease on all contact surfaces
- Arrange and align cable routing - brake lines can be positioned in the opposite position (Left – Rear, Right – Front)
- Install headset top cone (high or low stack) and spacers
- Install stem cable guide and gently position cables downward
- Install ICS Stem and steerer tube inserts
- Install top cap and compression bolt
△ **3Nm max torque**
- Install stem steerer clamp bolt - grease required
△ **7Nm max torque**
- Install stem cable clamp
- Install stem cable cover
- Install optional Junction A mounting unit

4.5 Finishing Assembly

- Assemble and adjust brake and drivetrain equipment per manufacturer's instructions

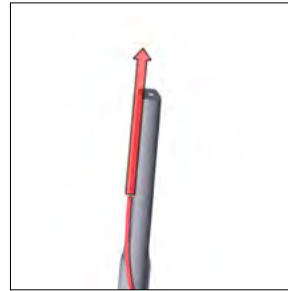

Route the front brake housing to the non-drive side

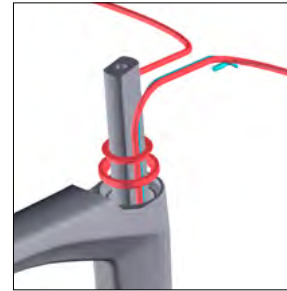

Install bearings and compression ring – cables will sit securely on flat sides of steerer tube

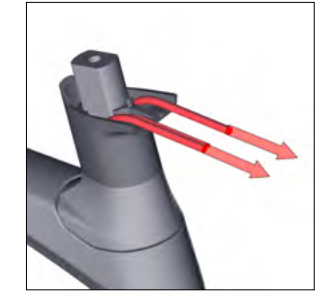

Install top cone, spacers and cable guide – gently fold cable downward



Install stem and steerer inserts



Install top cap



Install stem steerer clamp bolt - grease required!

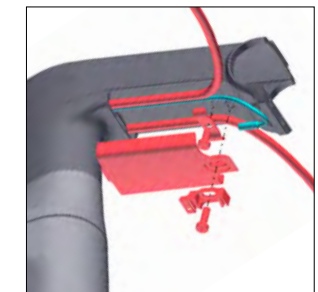

Install cable clamp and cable cover & Di2 junction box mount (optional)

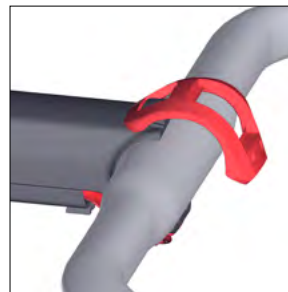

Install faceplate and faceplate cover – make sure the top faceplate 'puzzle' clamp is securely engaged

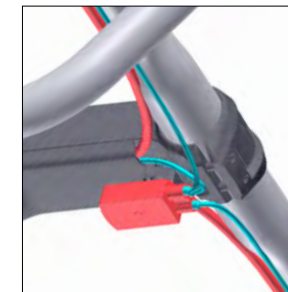
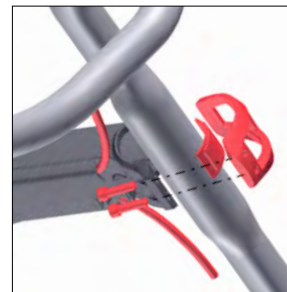

Install Di2 junction box (optional)